

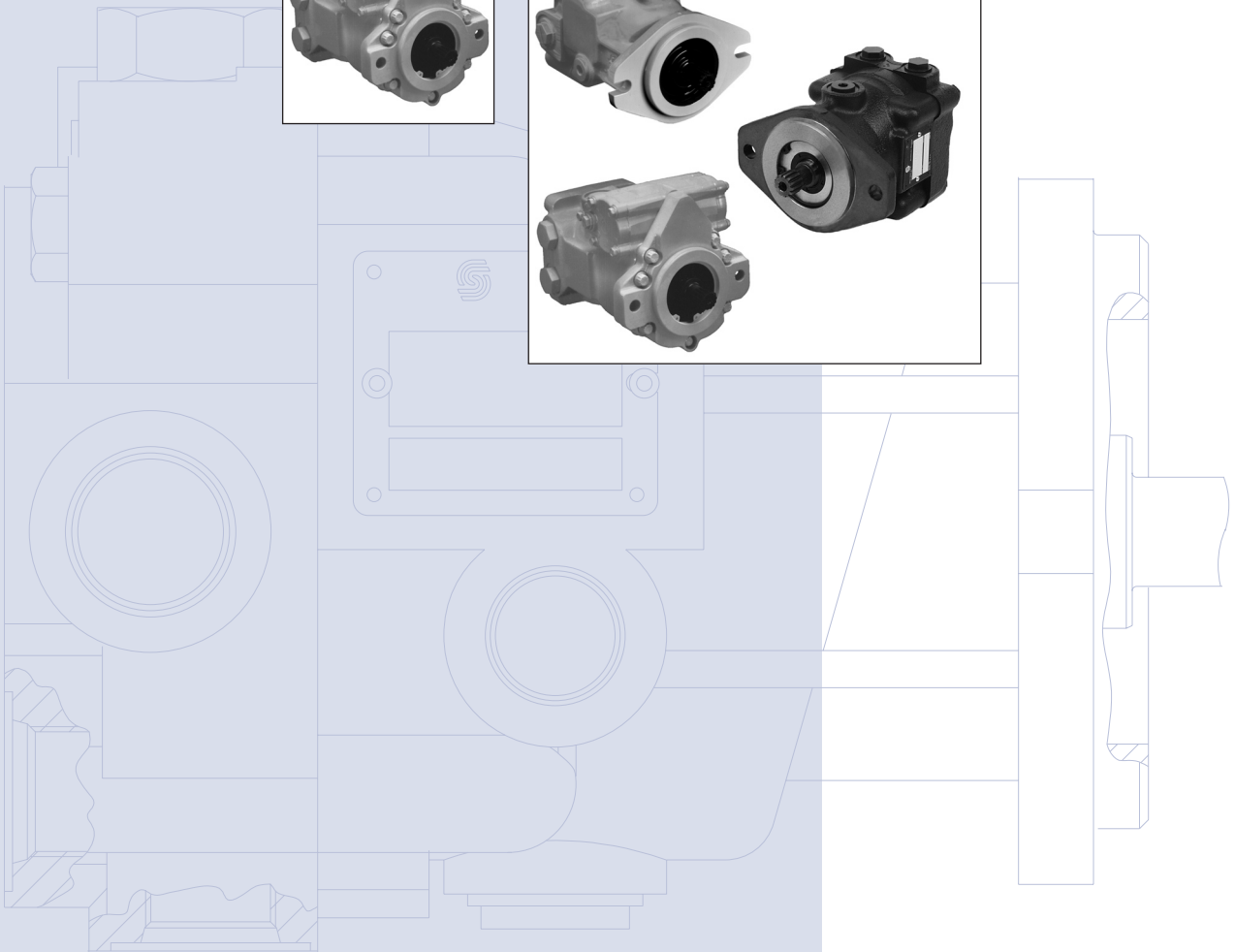

Series 40
Axial Piston
Motors

Technical
Information

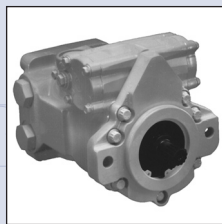
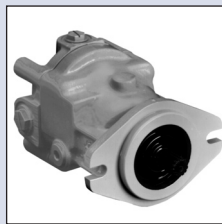

REVISIONS

Table of Revisions

Date	Page	Changed	Rev.
November 2007	31	correction to maximum torque rating 15 and 19 tooth	FB
April 2007	29	Revised dimensions for straight keyed shaft	FA
September-2006	21-22	Corrections in model code examples	F
September-2005		Major Revision	E

© 2007 Sauer-Danfoss. All rights reserved.

Sauer-Danfoss accepts no responsibility for possible errors in catalogs, brochures and other printed material. Sauer-Danfoss reserves the right to alter its products without prior notice. This also applies to products already ordered provided that such alterations aren't in conflict with agreed specifications. All trademarks in this material are properties of their respective owners. Sauer-Danfoss and the Sauer-Danfoss logotype are trademarks of the Sauer-Danfoss Group.

Front cover illustrations: F101 220, F101 221, F101 222, F101 223, P100 651E

GENERAL DESCRIPTION	Basic design.....	5
	Key features.....	6
	Cross sections.....	7
	System circuit diagram.....	8
	M46 motor schematic.....	8
TECHNICAL SPECIFICATIONS	Overview.....	9
	General.....	9
	Features and options.....	9
	Specifications.....	9
	Operating parameters.....	10
	Fluid specifications.....	10
	Hydraulic unit life.....	10
	Performance.....	11
	Bearing life and external shaft loading.....	12
OPERATING PARAMETERS	Fluids.....	14
	Viscosity.....	14
	Temperature.....	14
	Case pressure.....	14
	Pressure ratings.....	15
	Speed ratings.....	16
	SYSTEM DESIGN PARAMETERS	Sizing equations.....
Flow.....		17
Speed.....		17
Torque.....		17
Power.....		17
Variables.....		17
Filtration.....		18
Bypass valve.....		18
Loop flushing valve.....		19
Redundant braking system requirement.....		20
Reservoir.....		20
Overpressure protection.....		20
PRODUCT CODING	Revised model code.....	21
	Name plate.....	21
	Model code modules.....	21
	Fixed motor.....	21
	Variable motor.....	22
FEATURES AND OPTIONS	Displacement limiters.....	23
	Displacement limiter M35 MV.....	23
	Displacement limiter M46 MV.....	23
	Speed sensor option.....	24
	Pulse pickup and connector.....	25

FEATURES AND OPTIONS	Cross-section of speed sensor on cylinder kit	25
	Shaft options.....	26
	Through-shaft options	26
SHAFT OPTIONS	M25 MF	27
	M35/44 MF.....	28
	M35/44 MV	30
	M46 MV	31
CONTROL OPTIONS	Direct displacement control (DDC).....	32
	Two-position hydraulic control	33
INSTALLATION DRAWINGS	M25 MF: axial ports, twin ports, loop flushing, speed sensor.....	34
	M25 MF: mounting flange,	35
	M35/M44 MF: mounting flange.....	35
	M35/M44 MF: axial ports, twin ports, loop flushing, speed sensor	36
	M35/M44 MF: side ports, through shaft	37
	M35/M44 MV: twin ports	38
	M35/M44 MV: mounting flange, trunnion control.....	39
	M46 MV: side ports, loop flushing.....	40
	M46 MV: axial ports, loop flushing.....	41
	M46 MV: side ports, thru shaft twin ports, loop flushing.....	42
	M46 MV: mounting flange.....	43
	M46 MV: control ports	44
SCHEMATICS	M25/M35/M44 fixed motor schematics (no loop flushing)	45
	M25/M35/M44 fixed motor schematics.....	45
	M35/M44 variable motor schematics	45
	M46 variable motor schematics.....	45

BASIC DESIGN

Series 40 is a family of hydrostatic pumps and motors for medium power applications with maximum loads of 345 bar [5000 psi]. These pumps and motors can be applied together or combined with other products in a system to transfer and control hydraulic power.

Series 40 transmissions (pump plus motor) provide an infinitely variable speed range between zero and maximum in both forward and reverse modes of operation. The pumps and motors each come in four frame sizes: M25, M35, M44, and M46.

Series 40 pumps are compact, high power density units. All models use the parallel axial piston / slipper concept in conjunction with a tiltable swashplate to vary the pump's displacement. Reversing the angle of the swashplate reverses the flow of fluid from the pump, reversing the direction of rotation of the motor output.

Series 40 M35, M44, and M46 pumps may include an integral charge pump to provide system replenishing and cooling fluid flow, as well as servo control fluid flow on M46 pumps. M25 pumps are designed to receive charge flow from an auxiliary circuit or from a gear pump mounted on the auxiliary mounting pad. Series 40 pumps feature a range of auxiliary mounting pads to accept auxiliary hydraulic pumps for use in complementary hydraulic systems.

Series 40 M46 pumps offer proportional controls with either manual, hydraulic, or electronic actuation. An electric three-position control is also available. The M25, M35, and M44 pumps include a trunnion style direct displacement control.

Series 40 motors also use the parallel axial piston / slipper design in conjunction with a fixed or tiltable swashplate. The family includes M25, M35, M44 fixed motor units and M35, M44, M46 variable motor units.

The M35 and M44 variable motors feature a trunnion style swashplate and direct displacement control. The M46 variable motors use a cradle swashplate design and a two-position hydraulic servo control.

KEY FEATURES

- 4 sizes of variable displacement pumps
- 4 sizes of tandem pumps
- 3 sizes of variable displacement motors
- 3 sizes of fixed displacement motors
- Efficient axial piston design
- Complete family of control systems
- Proven reliability and performance
- Compact, lightweight
- Worldwide sales and service

CROSS SECTIONS

M25 fixed motor (MF)

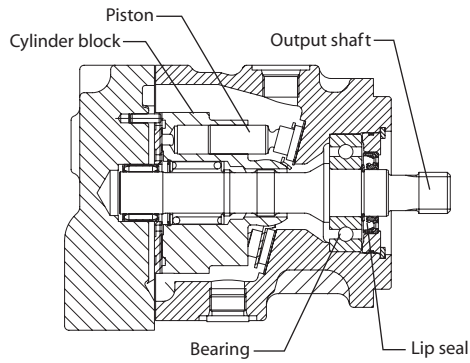

M35/M44 variable motor (MV)

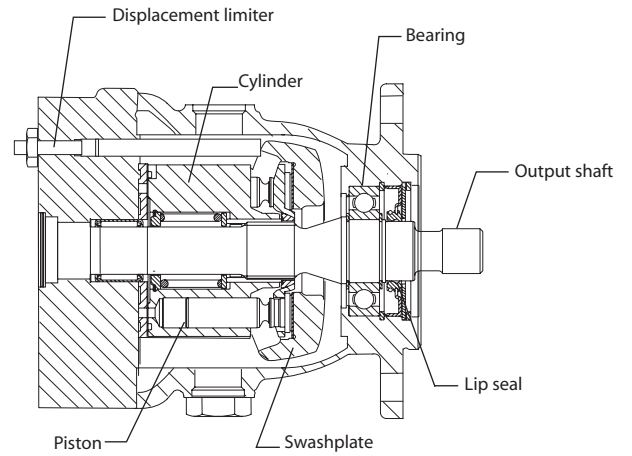

M35/M44 fixed motor (MF)

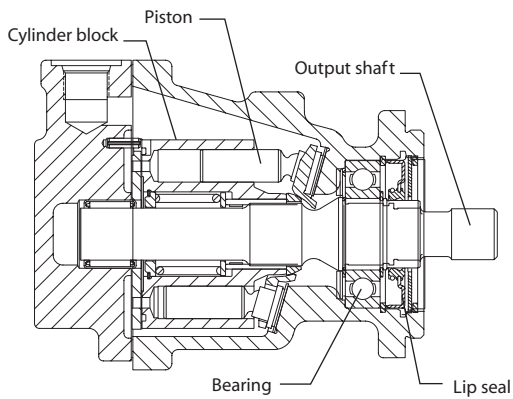

M46 variable motor (MV) (SAE flange)

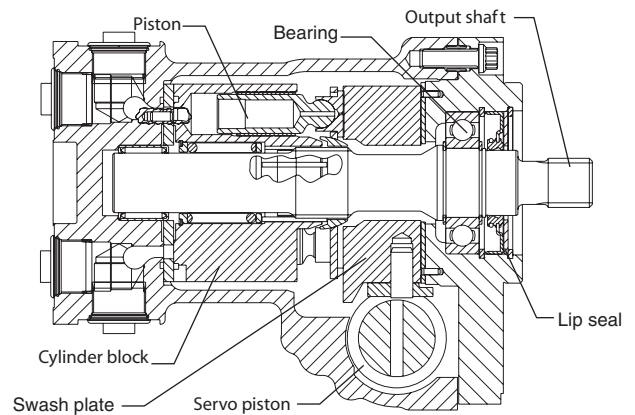

**SYSTEM CIRCUIT
DIAGRAM**

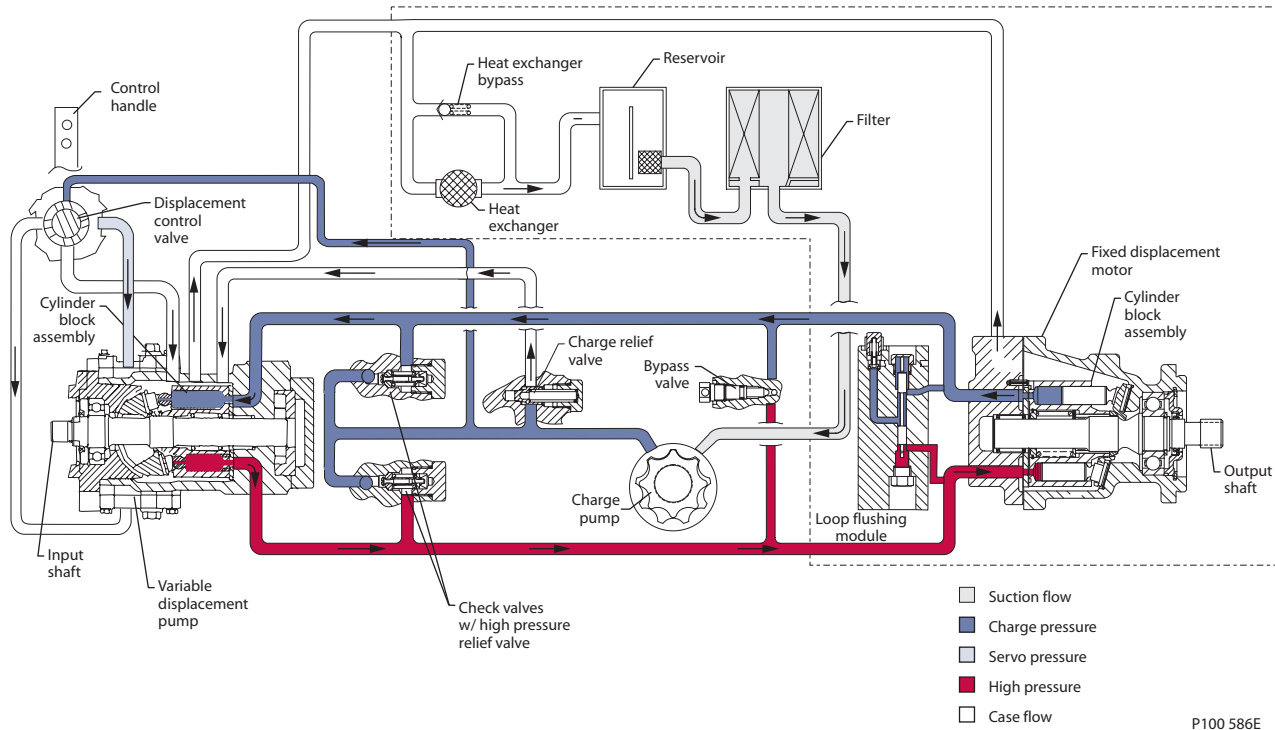

A Series 40 M35 fixed motor is shown in a hydraulic circuit with a Series 40 M46 variable pump. A loop flushing module is included on the motor. The circuit features suction filtration and heat exchanger.

M46 MOTOR SCHEMATIC

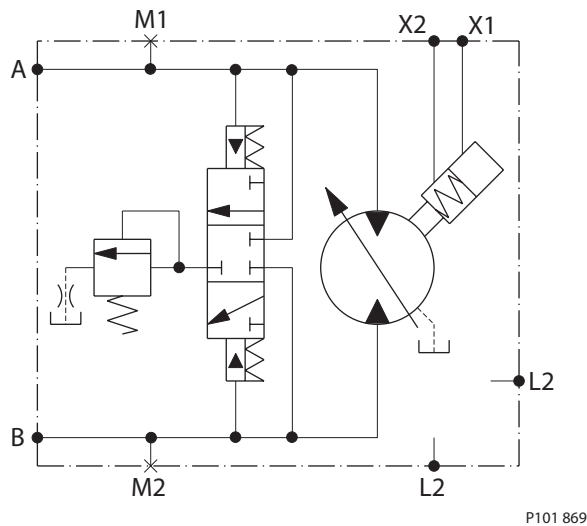

The system ports (A and B) connect to the high pressure work lines. The motor receives pressurized fluid in its inlet port and discharges de-energized fluid through the outlet port. Either port can act as inlet or outlet; flow is bidirectional. System port pressure is gauged through ports M1 and M2. The motor has two case drains (L1 and L2). The motor may include loop flushing. Loop flushing provides additional cooling and filtration capacity.

OVERVIEW

Specifications and operating parameters are shown below. Not all hardware options are available for all configurations. For additional information, see *Operating parameters*, page 14, *System design parameters*, page 17, *Product coding*, page 21, *Features and options*, page 23 and *Control options*, page 32.

GENERAL

Product line	Series 40 motors
Product type	In-line, axial piston, fixed and variable, positive displacement motors
Direction of rotation	Clockwise (CW) and counterclockwise (CCW)
Installation position	Discretionary, the housing must be filled with hydraulic fluid before operation
Filtration configuration	Suction or charge pressure filtration
Other system requirements	Independent braking system, circuit overpressure protection, suitable reservoir and heat exchanger

FEATURES AND OPTIONS

Model	M25 MF	M35 MF	M44 MF	M35 MV	M44 MV	M46 MV
Type of mounting	SAE B	SAE B	SAE B	SAE B	SAE B	SAE B or
Port connections	Twin, Axial	Side, Twin, Axial	Side, Twin, Axial	Twin	Twin	Side, Twin, Axial
Output shaft options	Splined Tapered	Splined Tapered Straight Key	Splined Tapered Straight Key	Splined	Splined	Splined Tapered
Control options	-	-	-	DDC	DDC	Hyd. 2-pos.
Loop flushing	Option	Option	Option	Option	Option	Option
Displacement limiters	-	-	-	Option	Option	Option
Speed sensors	Option	Option	Option	-	-	Option

SPECIFICATIONS

Model	Unit	M25MF	M35 MF	M44 MF	M35MV	M44MV	M46 MV
Model configuration		Fixed	Fixed	Fixed	Variable	Variable	Variable
Type of mounting		SAE B	SAE B	SAE B	SAE B	SAE B	SAE B
Displacement	cm ³ /rev [in ³ /rev]	25 [1.50]	35 [2.14]	44 [2.65]	35 [2.14]	44 [2.65]	46 [2.80]
Weight	kg [lbf]	11 [26]	11 [26]	11 [26]	21 [47]	21 [47]	23 [51]
Mass moment of inertia	kg·m ² [slug·ft ²]	0.0018 [0.0013]	0.0033 [0.0024]	0.0032 [0.0023]	0.0033 [0.0024]	0.0032 [0.0023]	0.0050 [0.0037]

**OPERATING
 PARAMETERS**

Model	M25 MF	M35 MF	M44 MF	M35 MV	M44 MV	M46 MV
Case pressure bar [psi]						
Continuous	1.7 [25]					
Maximum	5.2 [75]					
Speed limits min ⁻¹ [rpm]						
Rated @ max disp.	4000	3600	3300	3600	3300	4000
Maximum @ max. disp.	5000	4500	4100	4500	4100	4100
Rated @ min. disp.	-	-	-	4200	3900	4500
Maximum @ min. disp.	-	-	-	5300	4850	5000
System pressure bar [psi]						
Continuous	210 [3000]					
Maximum	345 [5000]					

FLUID SPECIFICATIONS

Ratings and data are based on operation with premium petroleum-based hydraulic fluids containing oxidation, rust, and foam inhibitors.

Parameter	Unit	Minimum	Continuous	Maximum
Viscosity	mm ² /sec (cSt) [SUS]	7 [47]	12-60 [70-278]	1600 [7500]
Temperature	°C [°F]	-40 [-40]	82 [180]	104 [220]
Cleanliness	ISO 4406 Class 18/13 or better			
Filtration efficiency	suction filtration	$\beta_{35-44}=75$ ($\beta_{10} \geq 1.5$)		
	charge filtration	$\beta_{15-20}=75$ ($\beta_{10} \geq 10$)		

HYDRAULIC UNIT LIFE

Hydraulic unit life is the life expectancy of the hydraulic components. Hydraulic unit life is a function of speed and system pressure; however, system pressure is the dominant operating variable affecting hydraulic unit life. High pressure, which results from high load, reduces expected life.

It is desirable to have a projected machine duty cycle with percentages of time at various loads and speeds. Sauer-Danfoss calculates appropriate design pressure from this information. This method of selecting operating pressure is recommended whenever duty cycle information is available.

HYDRAULIC UNIT LIFE
 (continued)

All pressure limits are differential pressures and assume normal charge pressure. Series 40 motors will meet satisfactory life expectancy if applied within the parameters specified in this bulletin. For more detailed information on hydraulic unit life see **BLN-9884 Pressure and Speed Limits**.

PERFORMANCE

This performance graph provides typical volumetric and overall efficiencies for Series 40 motors. These efficiencies apply for all Series 40 motors at maximum displacement.

Motor performance as a function of operating speed

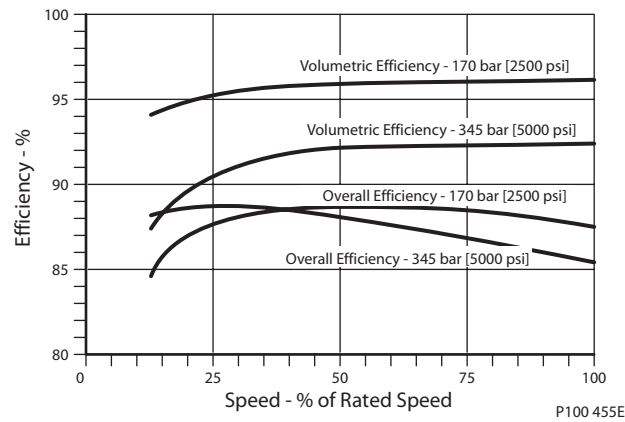

The performance map provides typical motor overall efficiencies at various operating parameters. These efficiencies apply for all Series 40 motors at maximum displacement.

Motor performance as a function of operating speed

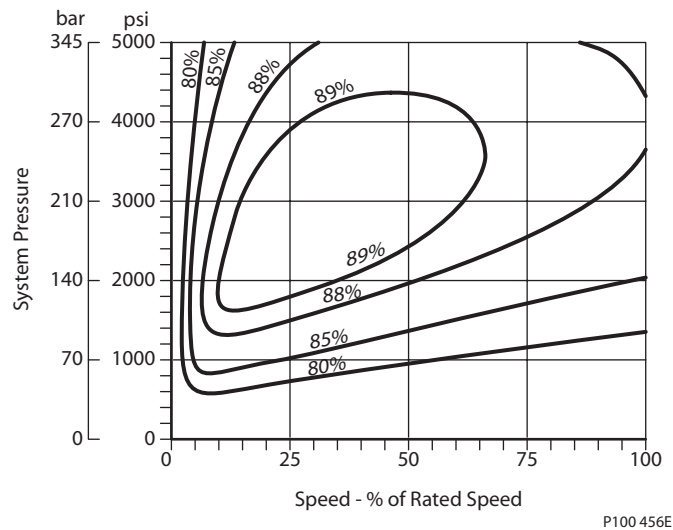

**BEARING LIFE AND
 EXTERNAL SHAFT
 LOADING**

Bearing life is a function of speed, pressure and swashplate angle, plus any external loads. Other life factors include oil type and viscosity.

In vehicle propulsion drives with no external loads, where the speed, pressure, and swashplate angle are often changing, normal bearing β_{10} (90% survival) life will exceed the hydraulic unit life.

In non-propel drives, such as conveyors or fan drives, the operating speed and pressure may be nearly constant leading to a distinctive duty cycle compared to that of a propulsion drive. In propel applications, Sauer-Danfoss recommends a bearing life review.

Series 40 motors are designed with bearings that can accept some incidental external radial and thrust loads. However, any amount of external load will reduce the expected bearing life.

The allowable radial shaft loads are a function of the load position, the load orientation, and the operating pressures of the hydraulic unit. All external shaft loads have an effect on bearing life. In motor applications where external shaft loads cannot be avoided, the impact on bearing life can be minimized by orienting the load to the 180 degree position (see *Direction of external shaft load*, next page).

The recommended maximum radial load (R_e) is based on an external moment (M_e) and the distance (L) from the mounting flange to the load, (see table at below). The loads in the table reflect a worst case external load orientation (0 degrees), a continuously applied working pressure of 140 bar (2000 psi), 20 bar (285 psi) charge pressure, 1800 min^{-1} (rpm), and a bearing life (β_{10}) of 2000 hours. Avoid thrust loads in either direction.

The recommended maximum allowable radial load is calculated as: $R_e = M_e / L$

If continuously applied external radial loads exceed the recommended maximum allowable, or thrust loads are known to occur, contact Sauer-Danfoss for an evaluation of unit bearing life. Optional high capacity bearings are available.

Tapered output shafts or clamp-type couplings are recommended for applications where radial shaft side loads are present.

Shaft loading parameters

R_e	Maximum radial side load
M_e	Maximum external moment
L	Distance from mounting flange to point of load
F_B	Force of block (applies at center of gravity)
T	Thrust load

Recommended maximum external shaft moments

	M25	M35/44	M46
M_e N·m [lbf·in]	29 [255]	25 [225]	24 [215]

**BEARING LIFE AND
EXTERNAL SHAFT
LOADING
(continued)**

External shaft loads

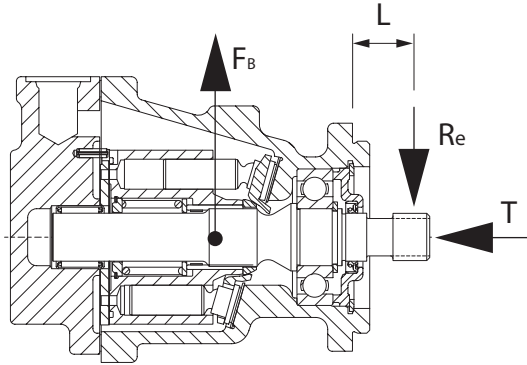

P100 453E

Direction of external shaft load

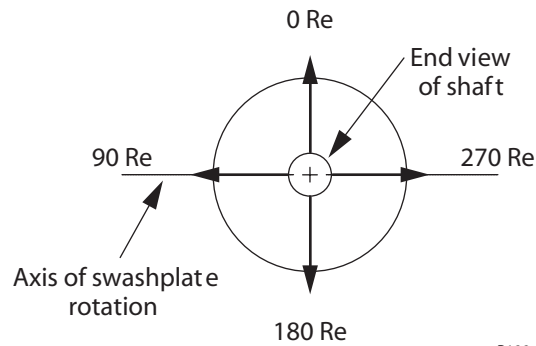

P100 454E

FLUIDS

Ratings and performance data are based on operating with premium hydraulic fluids containing oxidation, rust, and foam inhibitors. These include premium turbine oils, API CD engine oils per SAE J183, M2C33F or G automatic transmission fluids (ATF), Dexron™ II (ATF) meeting Allison™ C-3 or Caterpillar™ T0-2 requirements, and certain specialty agricultural tractor fluids. For more information on hydraulic fluid selection, see Sauer-Danfoss publications: **520L0463**, *Hydraulic Fluids and Lubricants, Technical Information*, and **520L465**, *Experience with Biodegradable Hydraulic Fluids, Technical Information*.

VISCOSITY

Maintain fluid viscosity within the continuous range for maximum efficiency and bearing life. **Minimum viscosity** should only occur during brief occasions of maximum ambient temperature and severe duty cycle operation. **Maximum viscosity** should only occur at cold start: Limit speeds until the system warms up. See Sauer-Danfoss publication: **520L0463**, *Hydraulic Fluids and Lubricants, Technical Information*

Fluid viscosity limits

Condition	mm ² /s (cSt)	SUS
Minimum	7	47
Continuous	12-60	70-278
Maximum	1600	7500

TEMPERATURE

Maintain fluid temperature within the limits shown in the table. **Minimum temperature** relates to the physical properties of the component materials. Cold oil will not affect the durability of the motor components. However, it may affect the ability of the motor to transmit power. **Maximum temperature** is based on material properties. Don't exceed it. Measure maximum temperature at the hottest point in the system. This is usually the case drain.

Temperature limits

Minimum (intermittent, cold start)	- 40° C [- 40° F]
Continuous	82.2° C [180° F]
Maximum	104.4° C [220° F]

Ensure fluid temperature and viscosity limits are concurrently satisfied.

CASE PRESSURE

Maintain case pressure within the limits shown in the table. Ensure housing is kept filled with hydraulic fluid.

Case pressure limits

Maximum (continuous)	1.7 bar [25 psi]
Intermittent (cold start)	5.2 bar [75 psi]

⚠ Caution

Operating outside of case pressure limits will damage the motor. To minimize this risk, use full size inlet and case drain plumbing, and limit line lengths.

PRESSURE RATINGS

The table, *Operating parameters*, page 10, gives maximum and continuous pressure ratings for each displacement. Not all displacements operate under the same pressure limits. Definitions of the operating pressure limits appear below.

System pressure is the differential pressure between system ports A and B. It is the dominant operating variable affecting hydraulic unit life. High system pressure, which results from high load, reduces expected life. System pressure must remain at or below continuous working pressure during normal operation to achieve expected life.

Continuous working pressure is the average, regularly occurring operating pressure. Operating at or below this pressure should yield satisfactory product life.

Maximum (peak) working pressure is the highest intermittent pressure allowed. Maximum machine load should never exceed this pressure. For all applications, the load should move below this pressure.

All pressure limits are differential pressures referenced to low loop (charge) pressure. Subtract low loop pressure from gauge readings to compute the differential.

System pressure limits

Pressure Limits	bar	psi
Continuous	210	3000
Maximum	345	5000

SPEED RATINGS

The table, *Operating parameters*, page 10, gives rated and maximum speeds for each displacement. Not all displacements operate under the same speed limits. Definitions of these speed limits appear below.

Rated speed is the maximum recommended operating speed at full power condition. Operating at or below this speed should yield satisfactory product life. In vehicle propel applications, maximum motor speed during unloaded, on-road travel over level ground should not exceed this limit.

Maximum speed is the highest operating speed permitted. Exceeding maximum speed reduces pump life and can cause loss of hydrostatic power and braking capacity. Never exceed the maximum speed limit under any operating conditions.

⚠ Warning

Unintended vehicle or machine movement hazard.

The loss of hydrostatic drive line power, in any mode of operation (forward, neutral, or reverse) may cause the system to lose hydrostatic braking capacity. You must provide a braking system, redundant to the hydrostatic transmission, sufficient to stop and hold the vehicle or machine in the event of hydrostatic drive power loss.

Speed limits

Limit min ⁻¹ (rpm)	M25 MF	M35 MF	M44 MF	M35 MV	M44 MV	M46 MV
Rated at max. displ...	4000	3600	3300	3600	3300	4000
Maximum at max. displ...	5000	4500	4100	4500	4100	4100
Rated at min. displ...	-	-	-	4200	3900	4500
Maximum at min. displ...	-	-	-	5300	4850	5000

SIZING EQUATIONS

Use the following equations to compute output power, torque, speed, and input flow. Selecting the right motor starts with an evaluation of system requirements such as speed and torque. Select a motor that will transmit the required torque, then select a pump that will meet the flow and pressure requirements of the motor. For more information on hydrostatic drive selection, refer to Sauer-Danfoss applications guideline **BLN-9885**, *Selection of Drive Line Components*.

Based on SI units

Flow Input flow Q = $\frac{V_g \cdot n}{1000 \cdot \eta_v}$ (l/min)

Speed Motor speed n = $\frac{Q \cdot 1000 \cdot \eta_v}{V_g}$ (min⁻¹)

Torque Output torque M = $\frac{V_g \cdot \Delta p \cdot \eta_m}{20 \cdot \pi}$ (N·m)

Power Output power P = $\frac{Q \cdot \Delta p \cdot \eta_t}{600}$ (kW)

Based on US units

Input flow Q = $\frac{V_g \cdot n}{231 \cdot \eta_v}$ (US gal/min)

Motor speed n = $\frac{Q \cdot 231 \cdot \eta_v}{V_g}$ (min⁻¹)

Output torque M = $\frac{V_g \cdot \Delta p \cdot \eta_m}{2 \cdot \pi}$ (lbf·in)

Output power P = $\frac{Q \cdot \Delta p \cdot \eta_t}{1714}$ (hp)

Variables SI units [US units]

V_g	= Displacement per revolution	cm ³ /rev [in ³ /rev]
p_o	= Outlet pressure	bar [psi]
p_i	= Inlet pressure	bar [psi]
Δp	= $p_o - p_i$ (system pressure)	bar [psi]
n	= Speed	min ⁻¹ (rpm)
η_v	= Volumetric efficiency	
η_m	= Mechanical efficiency	
η_t	= Overall efficiency ($\eta_v \cdot \eta_m$)	

FILTRATION

To prevent damage to the system, including premature wear, fluid entering the motor must be free of contaminants. Series 40 motors require system filtration capable of maintaining fluid cleanliness at ISO 4406-1999 class 22/18/13 or better.

Consider these factors when selecting a system filter:

- Cleanliness specifications
- Contaminant ingress rates
- Flow capacity
- Desired maintenance interval

The filter may be located either on the inlet (suction filtration) or discharge (charge pressure filtration) side of the charge pump. Series 40 pumps are available with provisions for either suction or charge pressure filtration to filter the fluid entering the charge circuit (see next page).

Typically, a filter with a beta ratio of $\beta_{10} = 1.5$ to 2.0 is adequate. However, open circuit systems supplied from a common reservoir may have considerably higher requirements. Because each system is unique, only a thorough testing and evaluation program can fully validate the filtration system. For more information, see Sauer-Danfoss publication **520L0467**, *Design Guidelines for Hydraulic Fluid Cleanliness*.

BYPASS VALVE

In some applications it is desirable to bypass fluid around the variable displacement pump, for example; to allow a vehicle to move short distances at low speeds without running the prime mover. This is done by opening a manually operated bypass valve. This valve connects both sides of the pump/motor circuit and allows the motor to turn. During normal operation, this valve must be fully closed .

Bypass valves are available in Series 40 pumps. See Sauer-Danfoss publication: **520L0635**, *Series 40 Pumps Technical Information*.

Bypass valves are intended for moving a machine or vehicle for very short distances at very slow speeds. They are NOT intended as tow valves.

LOOP FLUSHING VALVE

Series 40 motors may incorporate an integral loop flushing valve. Installations that require additional fluid to be removed from the main hydraulic circuit because of fluid cooling or cleanliness requirements, will benefit from loop flushing. A loop flushing valve will remove heat and contaminants from the main loop at a rate faster than otherwise possible. Contact your Sauer-Danfoss representative for production availability on specific frame size motors.

Series 40 loop flushing valves include a loop flushing relief valve with integral orifice. The flushing flow is a function of the pump charge relief valve, and the orifice size.

Loop flushing flows of 3 to 7 l/min [0.75 to 2 US gal/min] are adequate for most applications. Contact your Sauer-Danfoss representative for assistance.

▲ WARNING

Incorrect charge pressure settings may result in the inability to build required system pressure and/or inadequate loop flushing flows. Maintain correct charge pressure under all conditions.

Typical loop flushing flow as a function of charge pressure

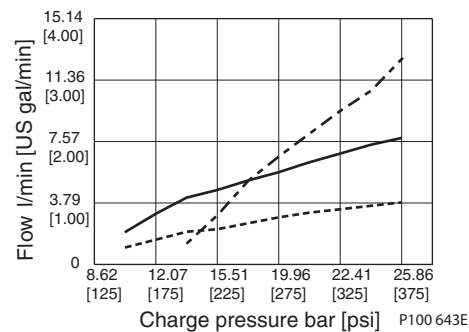

Loop flushing valve

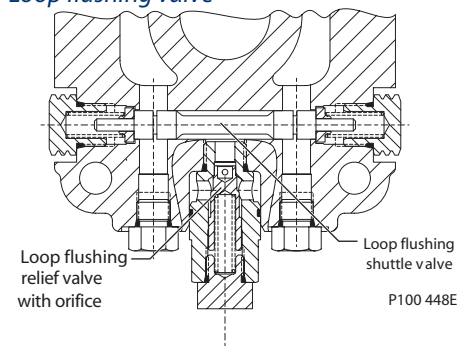

**REDUNDANT BRAKING
SYSTEM REQUIREMENT****⚠ Warning****Unintended vehicle or machine movement hazard.**

The loss of hydrostatic drive line power, in any mode of operation (forward, neutral, or reverse) may cause the system to lose hydrostatic braking capacity. You must provide a braking system, redundant to the hydrostatic transmission, sufficient to stop and hold the vehicle or machine in the event of hydrostatic drive power loss.

RESERVOIR

The reservoir provides clean fluid, dissipates heat, and removes entrained air from the hydraulic fluid. It allows for fluid volume changes associated with fluid expansion and cylinder differential volumes. Minimum reservoir capacity depends on the volume needed to perform these functions. Typically, a capacity of one half the charge pump flow (per minute) is satisfactory for a closed reservoir. Open circuit systems sharing a common reservoir will require greater fluid capacity.

Locate the reservoir outlet (suction line) near the bottom, allowing clearance for settling foreign particles. Use a 100 - 125 µm screen covering the outlet port. Place the reservoir inlet (return lines) below the lowest expected fluid level, as far away from the outlet as possible. Use a baffle (or baffles) between the reservoir inlet and outlet ports to reduce aeration and fluid surging.

**OVERPRESSURE
PROTECTION**

Series 40 motors (as well as other system components) have pressure limits. Relief valves or pressure limiters should be present in the high pressure circuit to protect components from excessive pressures.

Series 40 pumps are available with a range of high pressure relief valve settings. See Sauer-Danfoss publication **520L0635**, *Series 40 Pumps Technical Information*.

⚠ Caution

High pressure relief valves are intended for transient overpressure protection and are not intended for continuous pressure control. Operation over relief valves for extended periods of time may result in severe heat build up. High flows over relief valves may result in pressure levels exceeding the nominal valve setting and potential damage to system components.

REVISED MODEL CODE

The model code is a modular description of a specific product and its options. To create an order code to include the specific options desired, see the *Series 40 Motor Model Code Supplement* or the *Series 40 Price Book*.

NAME PLATE

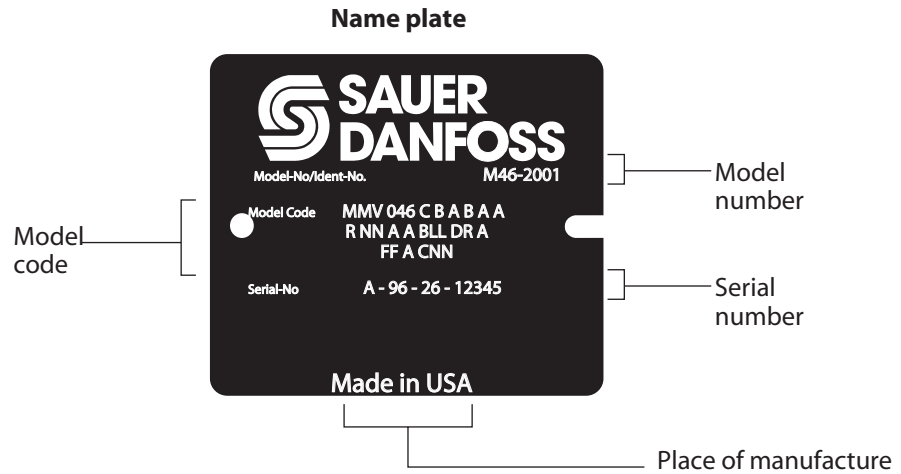

P101 372E

MODEL CODE MODULES

Fixed motor



P104 427E

- C** Seal group
- D** Output shaft/through shaft configuration
- E** Endcap configuration
- F** Cylinder block group
- G** Housing configuration
- T** Special hardware features
- Z** Special features (non-hardware) *** = None

**MODEL CODE MODULES
 (continued)**

Variable motor



P104 427E

- C** Seal group
- D** Output shaft/through shaft configuration
- E** Endcap configuration
- F** Control features
- G** Housing configuration
- T** Special hardware features
- Z** Special features (non-hardware) *** = None

DISPLACEMENT LIMITERS

▲ WARNING

Undesirable output speed hazard.

Take care adjusting displacement limiters. Too low of a minimum displacement setting can result in higher than expected output speed.

Retorque the sealing locknut after every adjustment to prevent an unexpected changes and to prevent external leakage.

M35, M44, and M46 variable motors have **minimum displacement limiters**. Minimum unit displacement is obtained with the adjuster screw at its maximum extension from the end cap or displacement control piston cover. All motors are shipped with the displacement limiter set for minimum motor displacement.

The M35 and M44 MV minimum displacement limiter is located in the end cap. The M46 MV minimum displacement limiter is located in the displacement control piston cavity. The length and configuration of this limiter will depend upon the control option installed in the motor.

M46 MV units may have an optional mechanical **maximum displacement limiter** located in the displacement control piston cover. The maximum displacement limit can be adjusted by loosening the sealing lock nut, adjusting displacement by rotating the screw with a screwdriver, then locking the adjuster by torquing the sealing lock nut.

Maximum unit displacement is obtained with the adjuster screw standing at its maximum height out of the displacement control piston cover. All motors are shipped with the limiter set for maximum motor displacement.

Displacement limiter M35/M44 MV

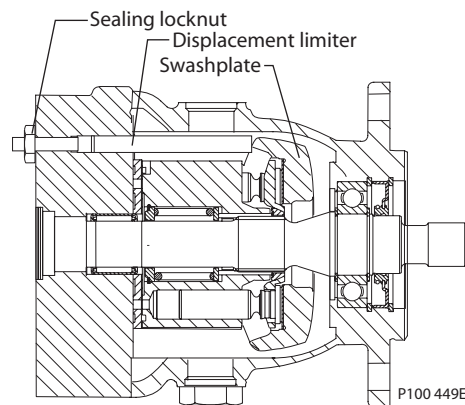

Displacement limiter M46 MV

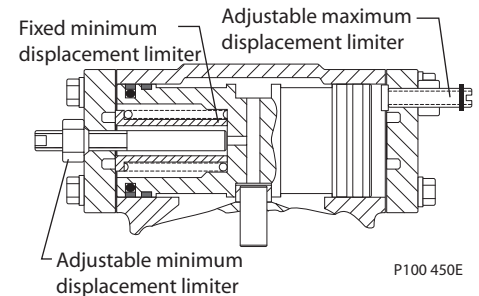

SPEED SENSOR OPTION

Series 40 motors are available with a speed sensor option for direct measurement of motor output speed. You can use this sensor may to sense the direction and speed of motor rotation.

A special magnetic speed ring is pressed onto the outside diameter of the cylinder block. A hall effect pulse pickup is located in the motor housing. The sensor accepts supply voltage and outputs a digital pulse signal in response to the speed of the ring. The output changes its high/low state as the north and south poles of the permanently magnetized speed ring pass by the face of the sensor. The digital signal is generated at frequencies suitable for microprocessor based controls.

This sensor will operate with a supply voltage of 4.5 to 15 Vdc, and requires a current of 12 mA at 5.0 Vdc (minimum) under no load. Maximum operating current is 20 mA at 5 Vdc (maximum). Maximum operating frequency is 15 kHz. Output voltage in High State (VOH) is sensor supply voltage minus 0.5 Vdc, minimum. Output voltage in Low State (VOL) is 0.5 Vdc, maximum. The sensor is available with a Packard Weather-Pack™ or 4-pin sealed connector.

Contact your Sauer-Danfoss representative for production availability on specific motor frame sizes, or for special speed sensor options.

Speed sensor specifications

Supply voltage	4.5 - 15 Vdc
Required current	12 mA @ 5 Vdc (no load)
Maximum current	20 mA @ 5Vdc
Maximum frequency	15 kHz
VOH	Supply Vdc - 0.5 Vdc
VOL	0.5 Vdc maximum
Magnetic ring Pulses/revolution	M25 M35 M44 M46 43 46 46 51
Connector	Packard Weather-Pack™ 3- pin, 4-pin

Speed sensor cross section

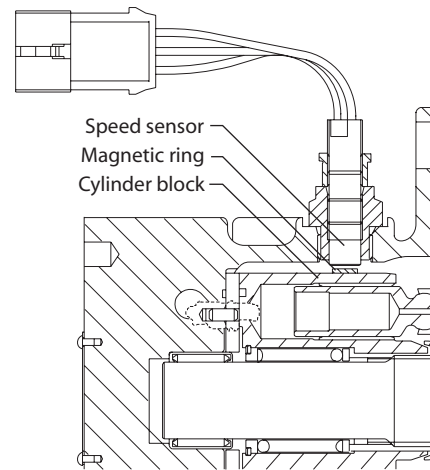

P100 452E

PULSE PICKUP AND CONNECTOR

Speed sensor with directional signal

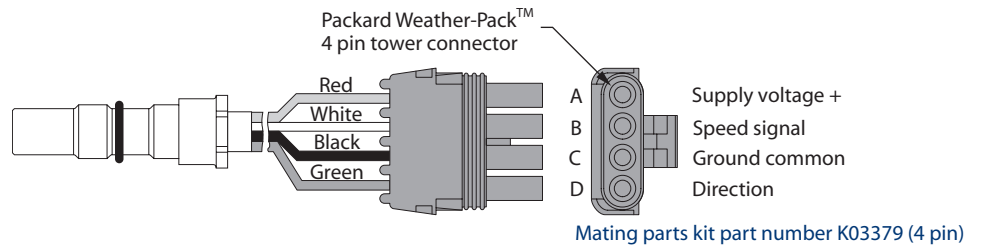

Speed sensor without directional signal

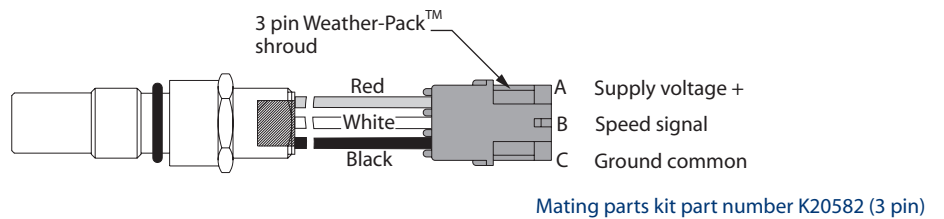

SHAFT OPTIONS

Series 40 motors are available with a variety of splined, straight keyed, and tapered shaft ends. Nominal shaft sizes and torque ratings for some available shafts are shown in the accompanying table. Other shaft options may exist. Contact your Sauer-Danfoss representative for availability.

Torque ratings assume no external radial loading. **Continuous torque** ratings for splined shafts are based on spline tooth wear, and assume the mating spline has a minimum hardness of R_c 55 to full spline depth and coupling has good lubrication.

Maximum torque ratings are based on shaft torsional strength and assume a maximum of 200,000 load reversals.

Shaft availability and torque ratings

N•m [lbf•in]		M25 MF	M35 MF	M44 MF	M35 MV	M44 MV	M46 MV
Spline 13-tooth, 16/32 pitch	Continuous	80 [750]	73 [650]	73 [650]	73 [650]	73 [650]	73 [650]
	Max	140 [1240]	226 [2000]	226 [2000]	226 [2000]	226 [2000]	226 [2000]
Spline 15-tooth, 16/32 pitch	Continuous	-	153 [1350]	153 [1350]	153 [1350]	153 [1350]	153 [1350]
	Max	-	362 [3200]	362 [3200]	362 [3200]	362 [3200]	362 [3200]
Spline 19-tooth 16/32 pitch	Continuous	-	-	-	-	-	194 [1710]
	Max	-	-	-	-	-	460 [4070]
Tapered 1.00 inch	Max	140 [1240]	497 [4400]	497 [4400]	-	-	497 [4400]
Straight keyed 0.875 inch	Max	-	226 [2000]	226 [2000]	-	-	-

Recommended mating splines for Series 40 splined output shafts should be in accordance with ANSI B92.1 Class 5. Sauer-Danfoss external splines are modified Class 5 Fillet Root Side Fit. The external spline Major Diameter and Circular Tooth Thickness dimensions are reduced in order to assure a clearance fit with the mating spline.

**THROUGH-SHAFT
 OPTIONS**

Optional through-shafts are available on Series 40 fixed and variable displacement motors (as noted in the accompanying table). Through-shafts are provided for use in secondary (parking) braking systems. Through-shaft ends are not intended for continuous power transmission.

Through-shaft availability and torque limitations

Frame size	Shaft spline	Max. torque limit N•m [lbf•in]
M35 MF	13T 16/32 P	328 [2900]
M44 MF	13T 16/32 P	328 [2900]
M46 MV(SAE)	13T 16/32 P	328 [2900]

▲ WARNING

Potential loss of braking capacity.

Exceeding these torque limits could cause shaft breakage. Ensure your application never exceeds maximum torque limits under any operating conditions.

M25 MF

Code	Description	Torque rating		Drawing
		Maximum torque rating N•m [lbf•in]	Continuous torque rating N•m [lbf•in]	
E	13-tooth 16/32 pitch (ANSI B92.1 1970 - Class 5)	140 [1240]	80 [750]	<p>P104 428E</p>
N	Ø 25.4 mm [1.000 in] 1:8 taper	140 [1240]	—	<p>P104 429E</p>

M35/44 MF

Code	Description	Torque rating		Drawing
		Maximum torque rating N·m [lbf·in]	Continuous torque rating N·m [lbf·in]	
A, C	Splined output shaft (see table)	13 tooth 226 [2000]	13 tooth 73 [650]	<p>W pitch dia. 30° pressure angle Y teeth, Z pitch fillet root side fit per ANSI B92.1-1970 class no.5 also mates with flat root side fit</p> <p>P104 430E</p>
F		15 tooth 362 [3200]	15 tooth 153 [1350]	

M35 / M44 MF splined shaft option

Shaft option	Shaft length S	Shaft diameter T	Full spline U	Major dia. V	Pitch dia. W	No. teeth Y	Pitch Z	Thru shaft
A	33.55 [1.321]	18.8 [0.74]	16.5 [0.65]	21.72 [0.8550]	20.638 [0.8125]	13	16/32	---
C	33.55 [1.321]	18.8 [0.74]	16.5 [0.65]	21.72 [0.8550]	20.638 [0.8125]	13	16/32	13T
F	33.55 [1.321]	21.98 [0.865]	18.5 [0.73]	24.89 [0.9800]	23.812 [0.9375]	15	16/32	---

M35/44 MF (CONTINUED)

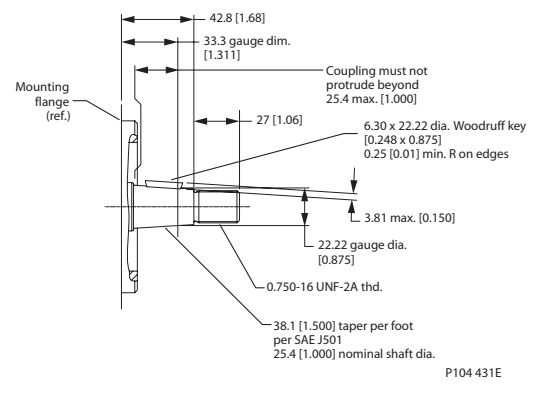
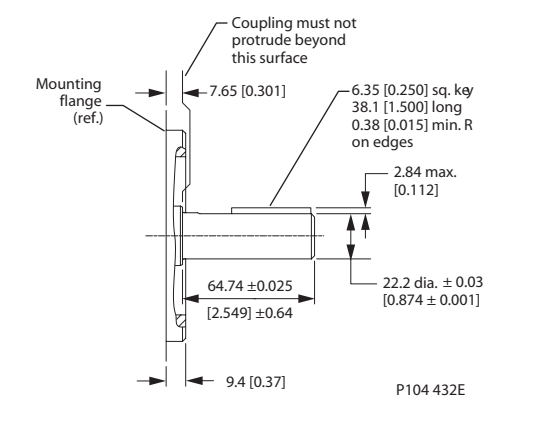
Code	Description	Torque rating		Drawing
		Maximum torque rating N•m [lbf•in]	Continuous torque rating N•m [lbf•in]	
N	Ø 25.4 mm [1.000 in] 1:8 taper	497 [4400]	—	
Y	Ø 22.2 mm [0.874 in] straight keyed	226 [2000]	—	

M35/44 MV

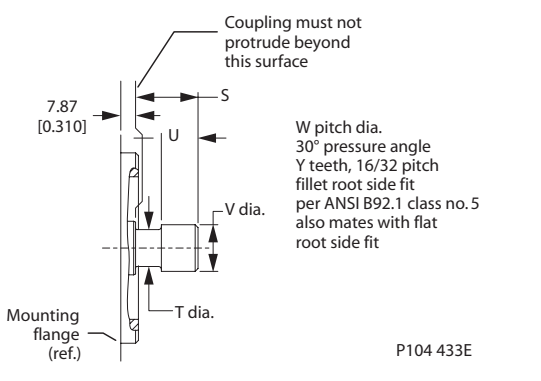
Code	Description	Torque rating		Drawing
		Maximum torque rating N·m [lbf·in]	Continuous torque rating N·m [lbf·in]	
A	Splined output shaft (see table)	73 [650]	226 [2000]	

M35 / M44 MV splined shaft option

Shaft option	Max. coupling engagement S	Shaft diameter T	Full spline length U	Major dia. V	Pitch dia. W	No. teeth Y	Pitch	Thru shaft
A	33.3 [1.31]	18.8 [0.74]	16.5 [0.65]	21.72 [0.855]	20.638 [0.8125]	13	16/32	---

M46 MV

Code	Description	Torque rating		Drawing
		Maximum torque rating N•m [lbf•in]	Continuous torque rating N•m [lbf•in]	
A, B,	Splined output shaft (see table)	13 tooth 226 [2000]	13 tooth 73 [650]	<p>P104 434E</p>
E, F,		15 tooth 362 [3200]	15 tooth 153 [1350]	
D		19 tooth 460 [4070]	19 tooth 194 [1710]	
J	25.4 [1.000] tapered shaft	—	497 [4400]	<p>P104 435E</p>

M46 MV splined shaft option

Shaft option	Shaft extension R	Max. coupling engagement S	Shaft diameter T	Full spline length U	Major dia. V	Pitch dia. W	No. teeth Y	Pitch Z	Thru shaft
A	32.94 [1.297]	32 [1.26]	19.1 [0.75]	15.8 [0.62]	21.72 [0.855]	20.638 [0.8125]	13	16/32	---
B	32.94 [1.297]	32 [1.26]	19.1 [0.75]	15.8 [0.62]	21.72 [0.855]	20.628 [0.8125]	13	16/32	13T
E	37.72 [1.485]	36.6 [1.44]	22.3 [0.88]	22.86 [0.90]	24.89 [0.980]	23.812 [0.9375]	15	16/32	---
F	37.72 [1.485]	36.6 [1.44]	22.3 [0.88]	22.86 [0.90]	24.89 [0.980]	23.812 [0.9375]	15	16/32	13T
D	37.72 [1.485]	36.6 [1.44]	28.4 [1.114]	22.35 [0.88]	31.24 [1.230]	30.162 [1.1875]	19	16/32	---

DIRECT DISPLACEMENT CONTROL (DDC)

The direct displacement control is available on either side of the M35 and M44 variable motors. It provides a simple, positive method of displacement control. Movement of the control shaft causes a proportional swashplate movement, thus varying the motor's displacement from full to minimum displacement.

⚠ WARNING

Unintended vehicle movement hazard.

Internal forces may not return the swashplate to the neutral position under all operating conditions.

Neutral position is not factory set, nor is there any internal neutral return mechanism. The application must include provisions for all control linkage and neutral return functionality.

External Control Handle Requirements

Maximum allowable trunnion torque is 79.1 N•m [700 lbf•in]. Minimum torque necessary to hold the swashplate per 70 bar of differential system pressure is 11.3 N•m [100 lbf•in]. Maximum trunnion angle is 16° for M35 and M44.

DDC on left side of M35 motor

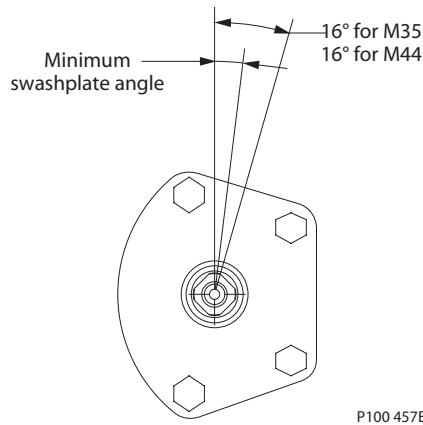

Motor displacement vs swashplate rotation

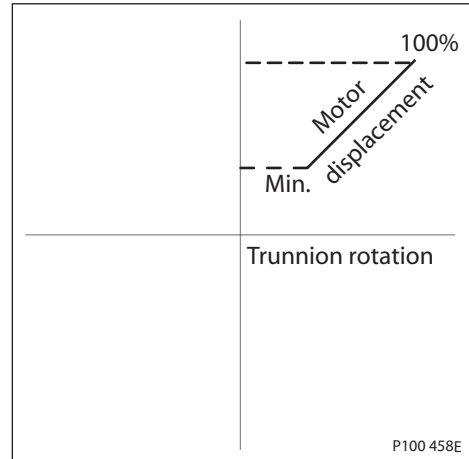

DDC input specifications

Max. torque N•m [lbf•in]	79.1 [700]
Min. torque to hold (per 70 bar [1000 psi] system pressure) N•m [lbf•in]	11.3 [100]
Max. angle	16°

**TWO-POSITION
 HYDRAULIC CONTROL**

Series 40 M46 variable displacement motors are equipped with a hydraulically controlled swashplate. The motor is spring biased toward maximum displacement. A hydraulic piston is used to shift the swashplate from maximum to minimum displacement. A single or two-line control can regulate the servo piston.

With the standard single-line control option, hydraulic pressure is supplied to the control port (X1) to shift the motor to minimum displacement. The opposite end of the displacement control piston internally drains to the motor case. The swashplate shifts with a minimum pressure of 13.8 bar [200 psi]. The bias spring returns the motor to maximum displacement when control pressure is removed.

The single-line control generally uses a customer supplied 2-position, 3-way control valve. Hydraulic pressure on the control piston must not exceed 27.6 bar [400 psi].

In applications which encounter frequent shifting on-the-go as part of the normal duty cycle, we recommend the optional two-line control. Applications with routine shifting from work range to travel range may not require the two-line control. To command minimum displacement, port control pressure to port X1 and drain port X2. To command maximum displacement, port control pressure to port X2 and drain port X1.

The two-line control generally uses a customer supplied 2-position, 4-way control valve. Hydraulic pressure on the control piston must not exceed 27.6 bar (400 psi).

Orifices in either (or both) the control valve supply and drain lines optimize the shift rate for either the single or two-line control. Contact your Sauer-Danfoss representative for additional information.

Input specifications bar [psi]

	Single line control	Two line control
Max. pressure on control	27.6 [400]	27.6 [400]
Min. pressure to shift	13.8 [200]	13.8 [200]
Control valve (customer supplied)	2-position / 3 way	2-position / 4-way

M46 2-position hydraulic controls

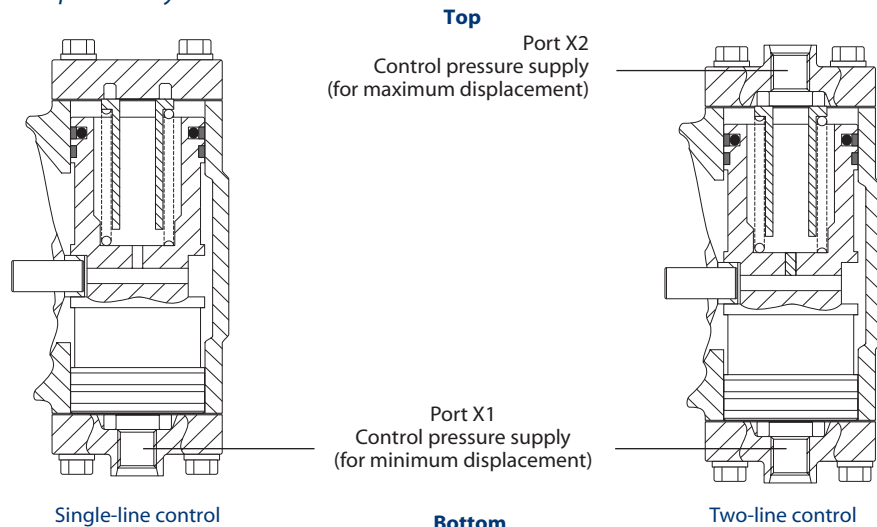

P100 459E

**M25 MF: AXIAL PORTS,
 TWIN PORTS, LOOP
 FLUSHING, SPEED
 SENSOR**

Flow direction

Motor shaft rotation	Port A	Port B
Clockwise (CW)	In	Out
Counterclockwise (CCW)	Out	In

Axial or twin ports

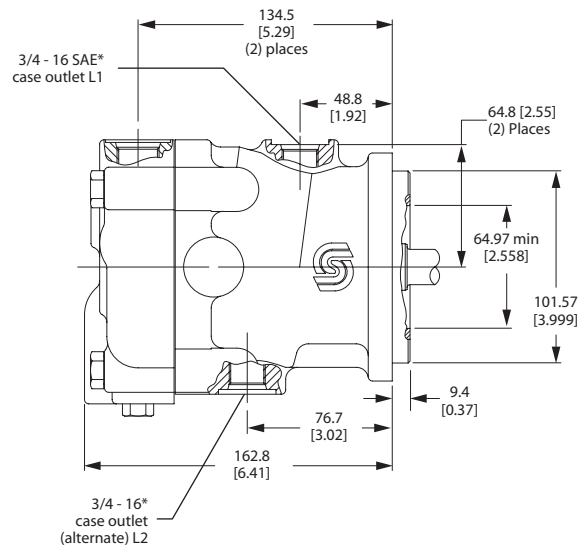
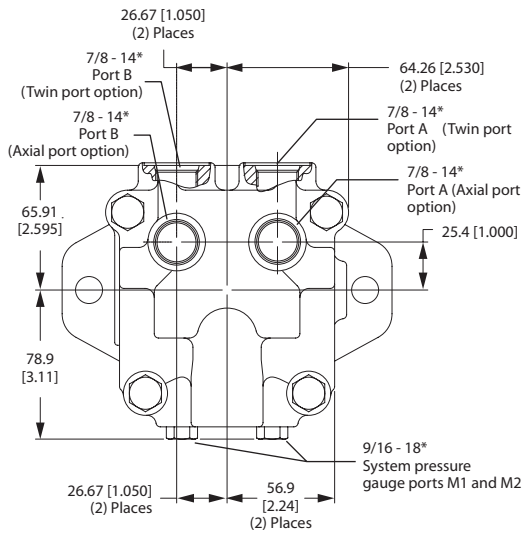

With loop flushing

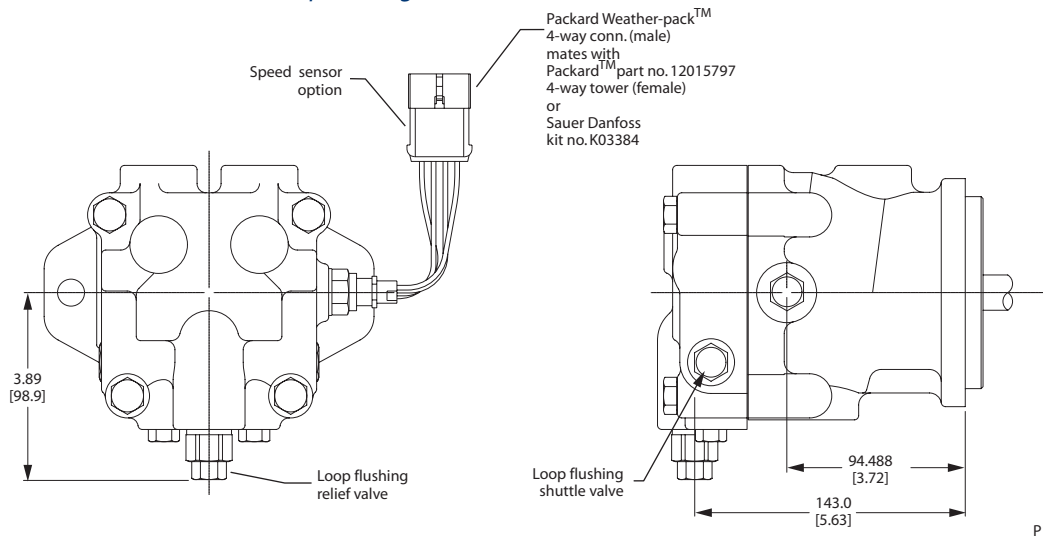

P100 565E

*All ports are SAE straight thread o-ring ports per SAE J514, unless otherwise specified.
 Shaft rotation is determined by viewing pump from input shaft end.
 Contact SAUER-DANFOSS Application Engineering for specific installation drawings.

Dimensions in mm [in]

**M25 MF: MOUNTING
 FLANGE**

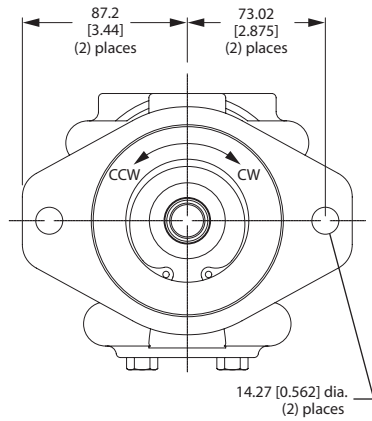

P100 566E

**M35/M44 MF: MOUNTING
 FLANGE**

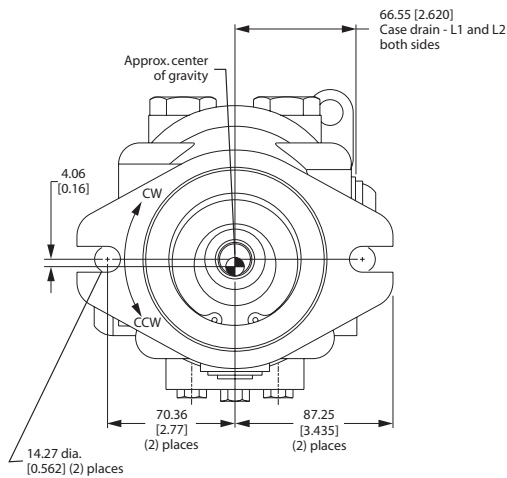

P100 569E

*All ports are SAE straight thread o-ring ports per SAE J514, unless otherwise specified.
 Shaft rotation is determined by viewing pump from input shaft end.
 Contact SAUER-DANFOSS Application Engineering for specific installation drawings.

Dimensions in mm [in]

M35/M44 MF: AXIAL PORTS, TWIN PORTS, LOOP FLUSHING, SPEED SENSOR

Flow direction

Motor shaft rotation	Port A	Port B
Clockwise	In	Out
Counterclockwise	Out	In

Axial ports

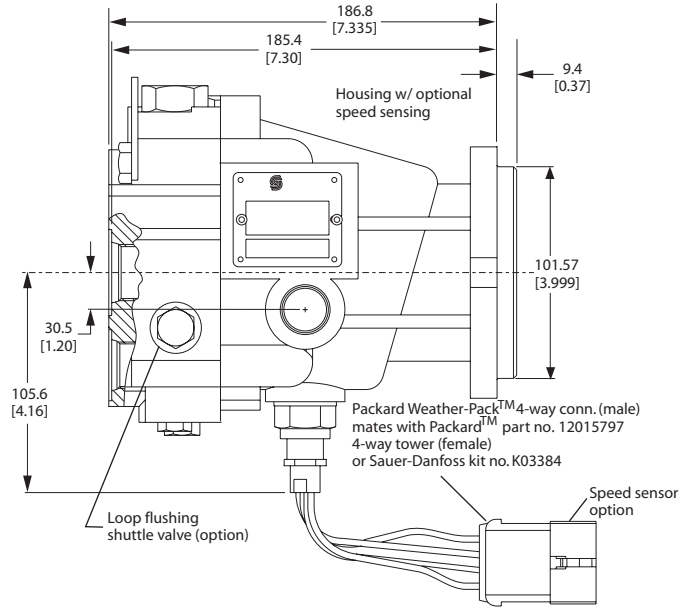
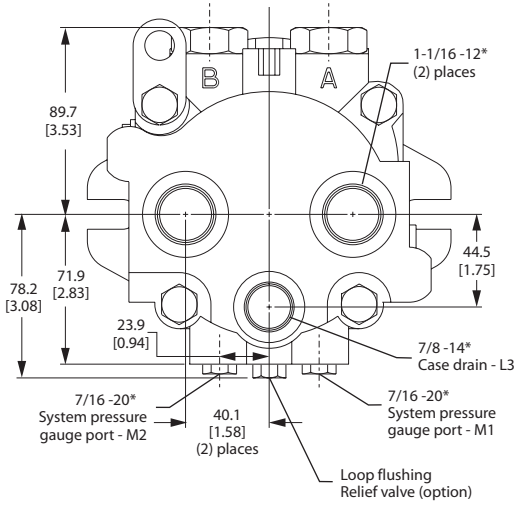

Twin ports

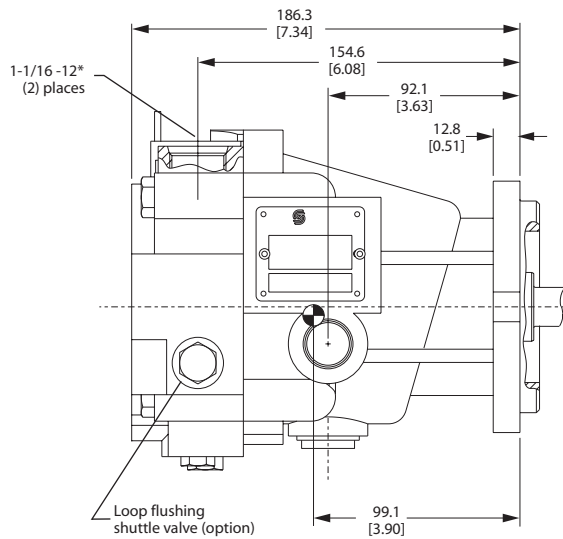
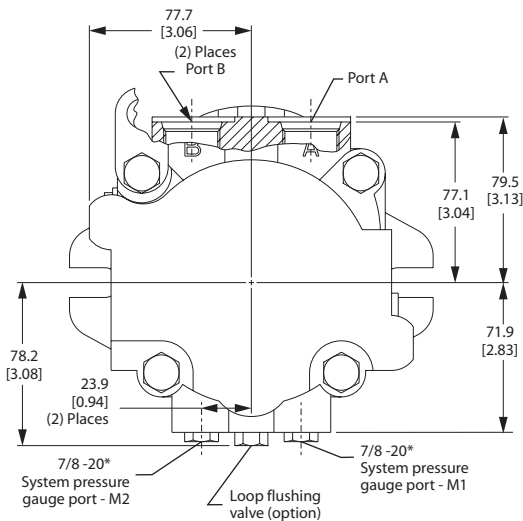

P100 567E

*All ports are SAE straight thread o-ring ports per SAE J514, unless otherwise specified.
 Shaft rotation is determined by viewing pump from input shaft end.
 Contact SAUER-DANFOSS Application Engineering for specific installation drawings.

Dimensions in mm [in]

M35/M44 MF: SIDE PORTS, THROUGH SHAFT

Side ports

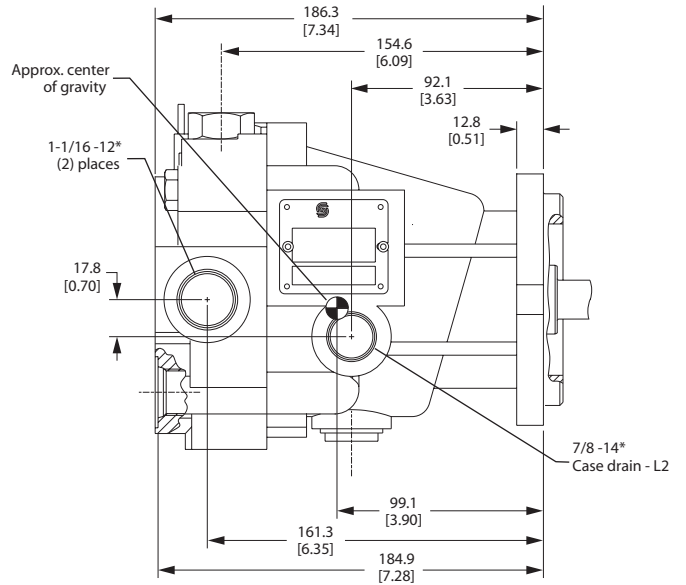
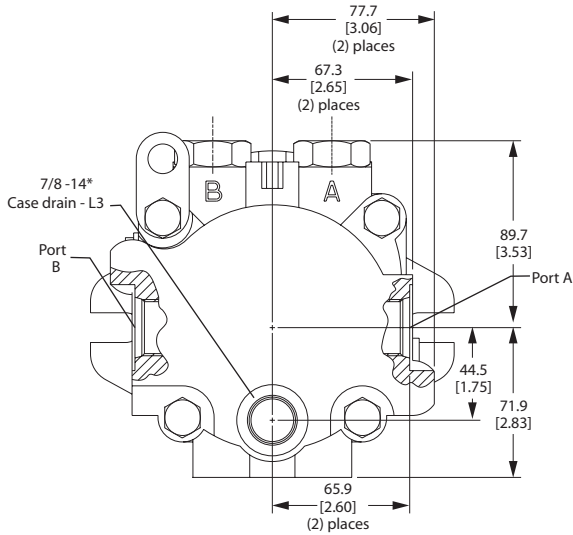

Side ports with thru shaft

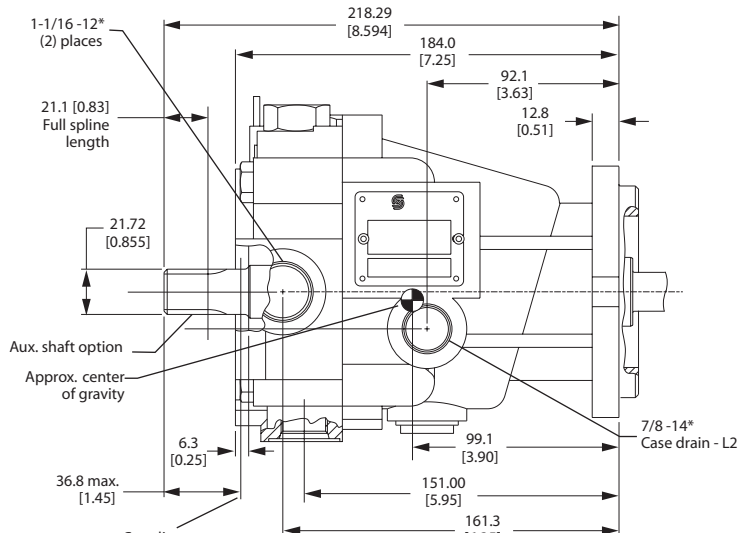
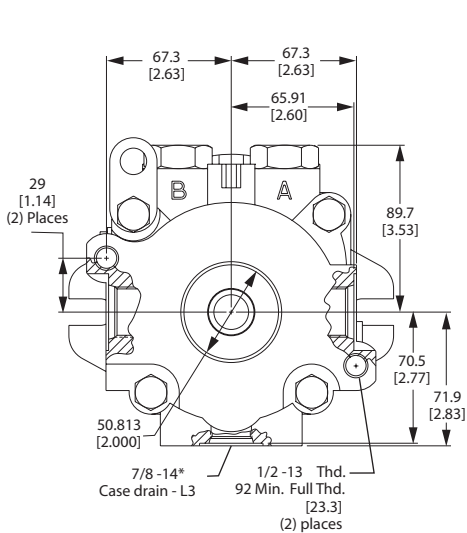

Auxiliary drive spline data:
 20.638 pitch diameter [0.8125]
 30° pressure angle
 13 teeth, 16/32 pitch
 fillet root side fit
 ANSI B92.1-1790 class no.5
 also mates with flat
 root side fit

Coupling must not protrude beyond this surface

P100 568E

*All ports are SAE straight thread o-ring ports per SAE J514, unless otherwise specified.
 Shaft rotation is determined by viewing pump from input shaft end.
 Contact SAUER-DANFOSS Application Engineering for specific installation drawings.

Dimensions in mm [in]

**M35/M44 MV: TWIN
 PORTS**

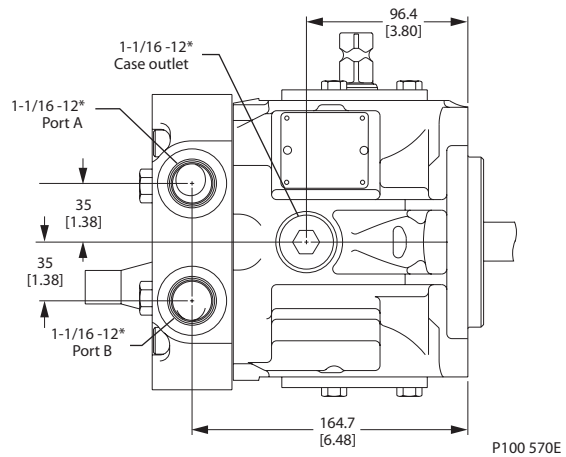
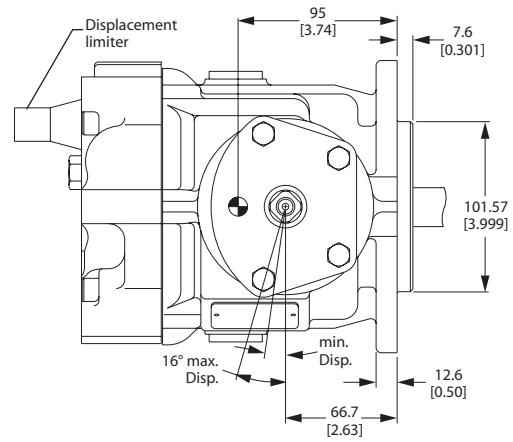
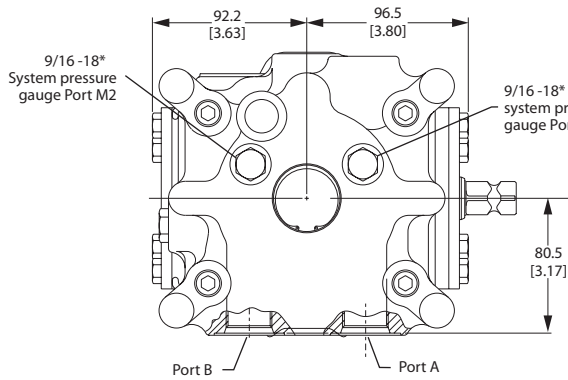

*All ports are SAE straight thread o-ring ports per SAE J514, unless otherwise specified.
 Shaft rotation is determined by viewing pump from input shaft end.
 Contact SAUER-DANFOSS Application Engineering for specific installation drawings.

**M35/M44 MV:
 MOUNTING FLANGE,
 TRUNNION CONTROL**

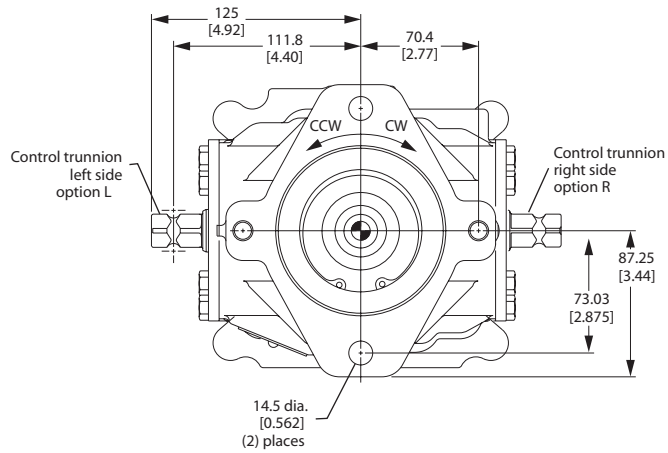

Trunnion control

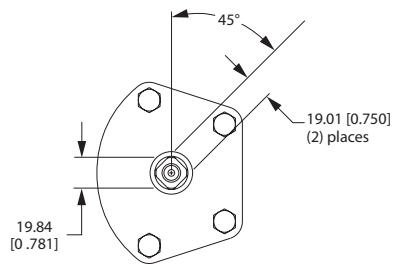

P100 571E

*All ports are SAE straight thread o-ring ports per SAE J514, unless otherwise specified.
 Shaft rotation is determined by viewing pump from input shaft end.
 Contact SAUER-DANFOSS Application Engineering for specific installation drawings.

**M46 MV: SIDE PORTS,
 LOOP FLUSHING**

Flow direction

Motor shaft direction	Port A	Port B
Clockwise (CW)	Out	In
Counterclockwise (CCW)	In	Out

Radial (side) ports w/o loop flushing

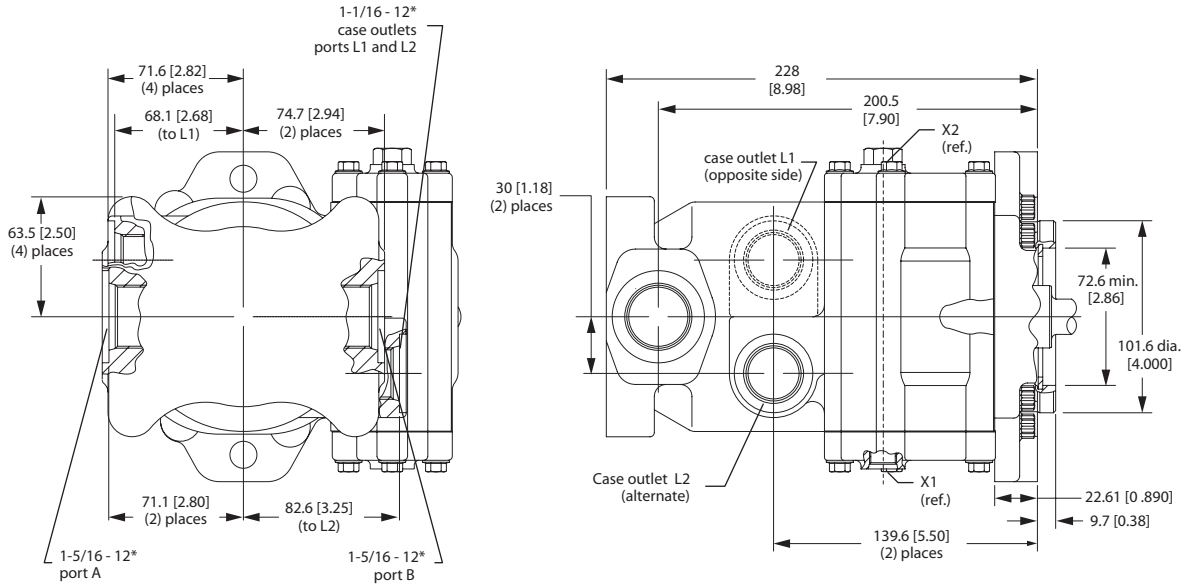

Radial (side) ports w/ loop flushing

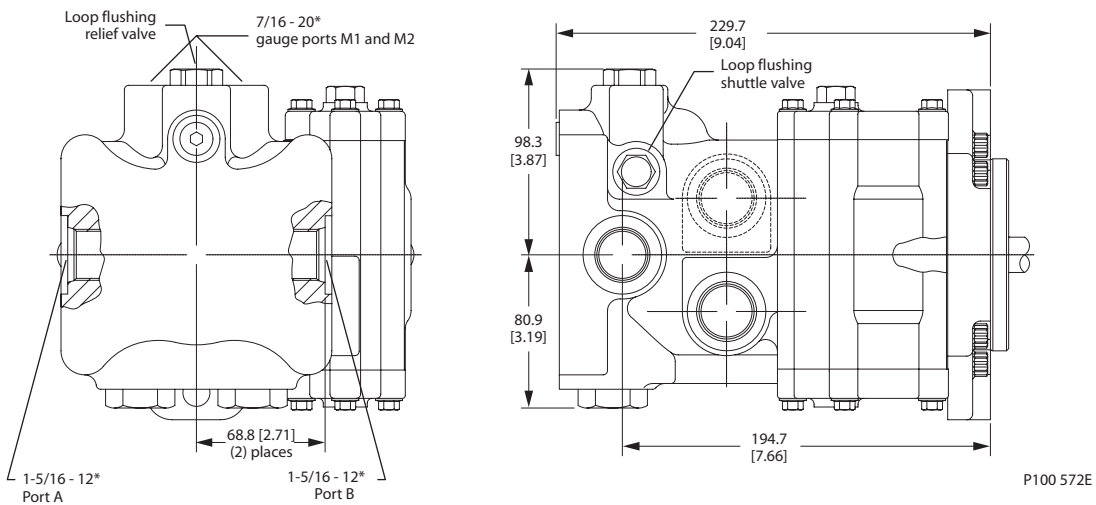

*All ports are SAE straight thread o-ring ports per SAE J514, unless otherwise specified.
 Shaft rotation is determined by viewing pump from input shaft end.
 Contact SAUER-DANFOSS Application Engineering for specific installation drawings.

Dimensions in mm [in]

**M46 MV: AXIAL PORTS,
 LOOP FLUSHING**

Axial ports w/ loop flushing

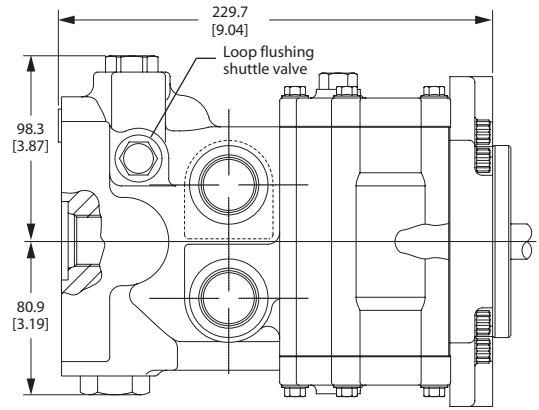
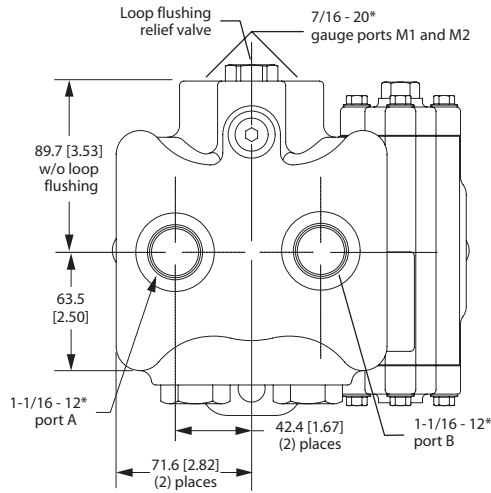

P100 573E

*All ports are SAE straight thread o-ring ports per SAE J514, unless otherwise specified.
 Shaft rotation is determined by viewing pump from input shaft end.
 Contact SAUER-DANFOSS Application Engineering for specific installation drawings.

Dimensions in mm [in]

**M46 MV: SIDE PORTS,
 THRU SHAFT TWIN
 PORTS, LOOP FLUSHING**

Side ports w/ thru shaft

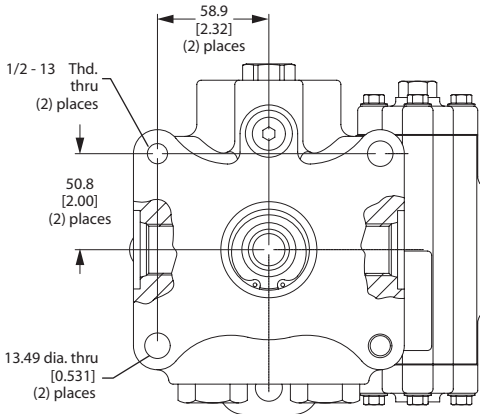

*Radial (side) ported w/ loop flushing
 w/ thru shaft*

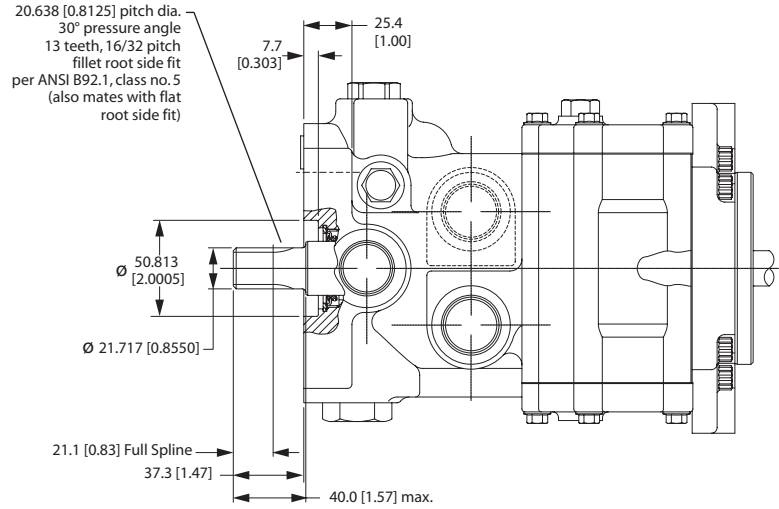

Radial (twin) ports w/ loop flushing

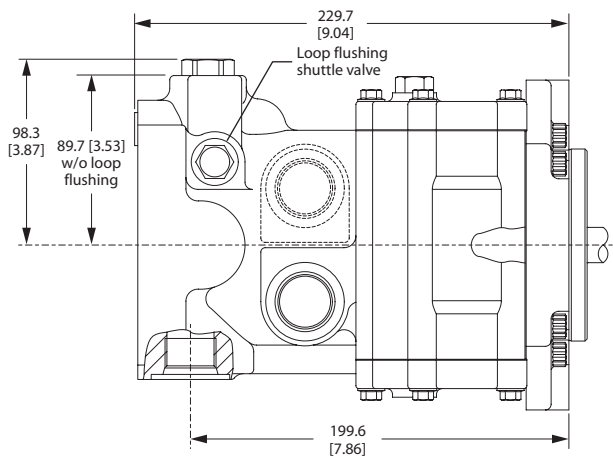
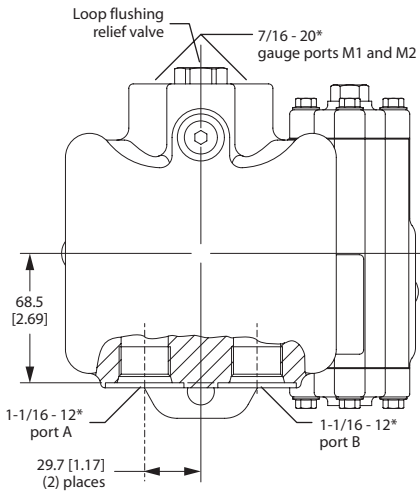

P100 574E

*All ports are SAE straight thread o-ring ports per SAE J514, unless otherwise specified.
 Shaft rotation is determined by viewing pump from input shaft end.
 Contact SAUER-DANFOSS Application Engineering for specific installation drawings.

Dimensions in mm [in]

**M46 MV: MOUNTING
 FLANGE**

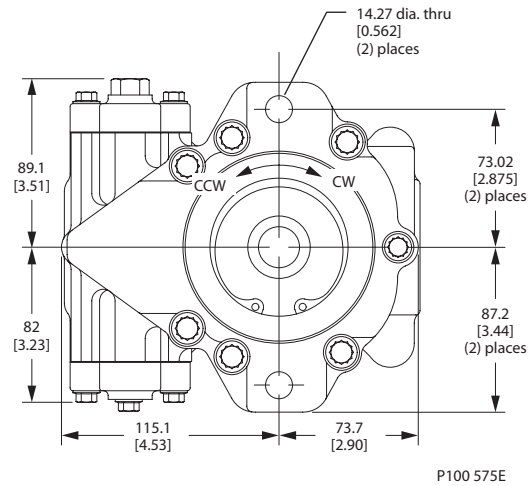

*All ports are SAE straight thread o-ring ports per SAE J514, unless otherwise specified.
 Shaft rotation is determined by viewing pump from input shaft end.
 Contact SAUER-DANFOSS Application Engineering for specific installation drawings.

Dimensions in mm [in]

**M46 MV: CONTROL
 PORTS**

Control w/ bottom pressure supply port and externally adjustable displacement limiters

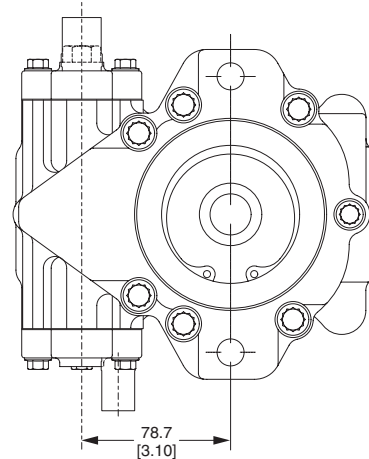
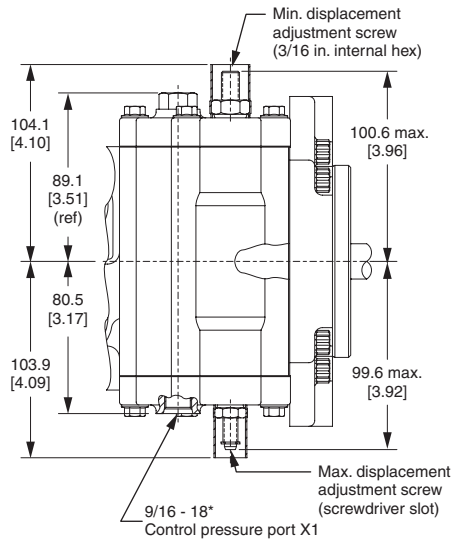

Control w/ top and bottom pressure supply ports

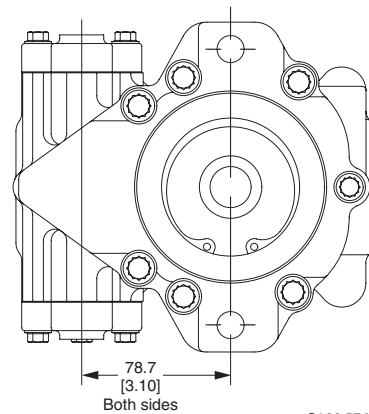
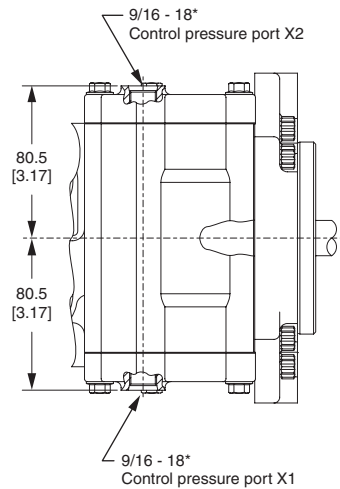

P100 576E

*All ports are SAE straight thread o-ring ports per SAE J514, unless otherwise specified.
 Shaft rotation is determined by viewing pump from input shaft end.
 Contact SAUER-DANFOSS Application Engineering for specific installation drawings.

Dimensions in mm [in]

**M25/M35/M44
FIXED MOTOR
SCHEMATICS
(NO LOOP FLUSHING)**

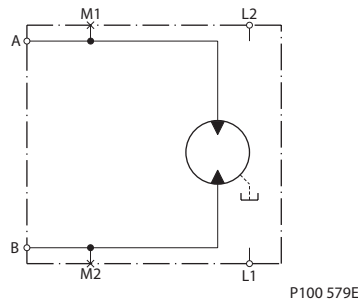

**M25/M35/M44
FIXED MOTOR
SCHEMATICS**

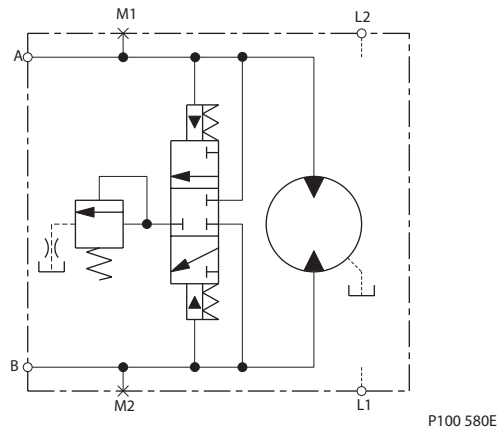

**M35/M44
VARIABLE MOTOR
SCHEMATICS**

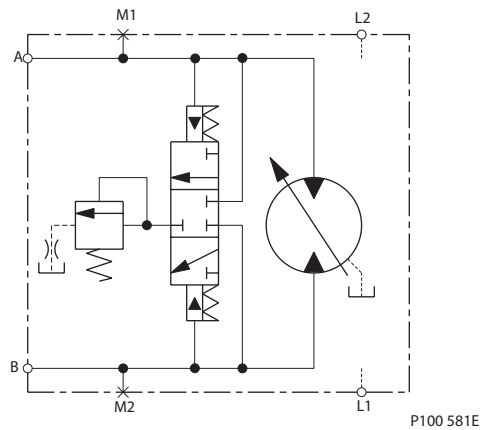

**M46
VARIABLE MOTOR
SCHEMATICS**

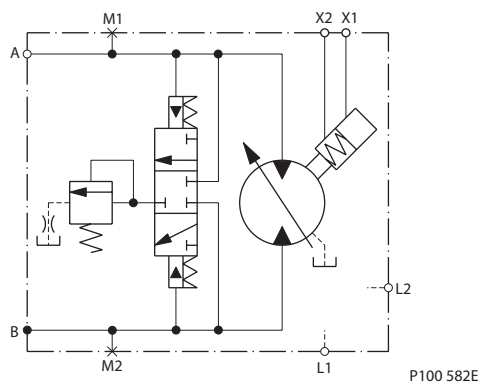



Series 40 Axial Piston Motors
Technical Information
Notes



Series 40 Axial Piston Motors
Technical Information
Notes



OUR PRODUCTS

Hydrostatic transmissions
Hydraulic power steering
Electric power steering
Electrohydraulic power steering
Closed and open circuit axial piston pumps and motors
Gear pumps and motors
Bent axis motors
Orbital motors
Transit mixer drives
Planetary compact gears
Proportional valves
Directional spool valves
Cartridge valves
Hydraulic integrated circuits
Hydrostatic transaxles
Integrated systems
Fan drive systems
Electrohydraulics
Microcontrollers and software
Electric motors and inverters
Joysticks and control handles
Displays
Sensors

Sauer-Danfoss Mobile Power and Control Systems – Market Leaders Worldwide

Sauer-Danfoss is a comprehensive supplier providing complete systems to the global mobile market.

Sauer-Danfoss serves markets such as agriculture, construction, road building, material handling, municipal, forestry, turf care, and many others.

We offer our customers optimum solutions for their needs and develop new products and systems in close cooperation and partnership with them.

Sauer-Danfoss specializes in integrating a full range of system components to provide vehicle designers with the most advanced total system design.

Sauer-Danfoss provides comprehensive worldwide service for its products through an extensive network of Global Service Partners strategically located in all parts of the world.

Local address:

Sauer-Danfoss (US) Company
2800 East 13th Street
Ames, IA 50010, USA
Phone: +1 515 239-6000
Fax: +1 515 239-6618

Sauer-Danfoss ApS
DK-6430 Nordborg, Denmark
Phone: +45 7488 4444
Fax: +45 7488 4400

Sauer-Danfoss GmbH & Co. OHG
Postfach 2460, D-24531 Neumünster
Krokamp 35, D-24539 Neumünster, Germany
Phone: +49 4321 871-0
Fax: +49 4321 871 122

Sauer-Danfoss-Daikin LTD
Sannomiya Grand Bldg. 8F
2-2-21 Isogami-dori, Chuo-ku
Kobe, Hyogo 651-0086, Japan
Phone: +81 78 231 5001
Fax: +81 78 231 5004